

LIGHTINGCONCEPTS









**AXO LIGHT LIGHTING CONCEPTS**

**ART DIRECTOR**

LORENZO TRUANT

**GRAPHIC DESIGN**

FACCHINETTI + FORTUNA

**EDITING**

SARA GUERRINI

**PHOTO**

FLORINDO ROMANDINI

**DTP & COLOR**

[WWW.IMAGENVIRONMENT.COM](http://WWW.IMAGENVIRONMENT.COM)

**PRINTED**

GRAFICHE TINTORETTO

**THANKS TO**

THE ARTIST TULLIO SILA  
FOR THE PAINTINGS ON THE PHOTOS

BONALDO S.P.A. FOR THE SUPPLY  
OF SOME FURNITURE

**BE YOUR LIGHT**



# LIGHTING CONCEPTS

NEW AXO LIGHT HEADQUARTERS





8



26



42



54



74





## **INDEX**

8	<b>OBI</b>
26	<b>AX20</b>
42	<b>UKIYO</b>
54	<b>MUSE</b>
74	<b>NELLY</b>
88	<b>TECHNICAL DATA</b>



PROGETTO OUTDOOR PER CASA NELLA SPAGNA  
SALVADORA... Principia

Alla coltura  
con la cultura  
di...

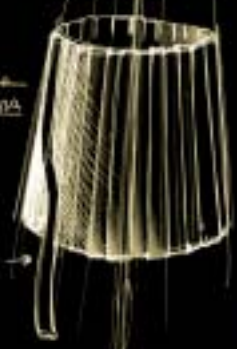

oro / rama



standing stabilia  
filo d'oro  
filo d'oro

dalle due da basso, in  
originales / custom  
in metallo o in alluminio



ca. 100

Per il metallo  
e l'oro d'oro  
Adattare il tutto con il  
sistema per il  
cavo di collegamento

Accessorie



Alle volte per il (2)+(3)  
della lampada in  
cavo unico

Dimensione della  
lampada dipende  
dalla lunghezza  
di cavo



非直線



PROGRAMMA GIAP.  
BI OBI - CITTÀ

© BI

Lampada da Tella dell'epoca  
al Museo 175 - 180 di più

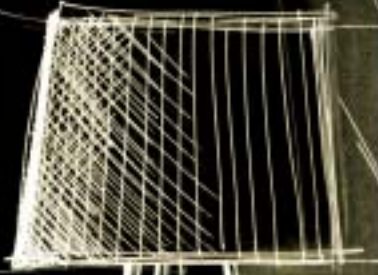

# 170-  
cm



帯



OBBI



Collezione completa di lampade con finitura cromo. Il paralume ed il rosone sono costituiti da fettucce setate colore avorio o nero e da un foglio interno semiriflettente finito cromo.

Complete lamp collection with chrome-plated fittings. The lampshades and the canopies consist of silken ribbons available in ivory or black and of a semi-reflecting chrome-plated finished sheet inside.

Komplette Leuchtenkollektion mit verchromtem Gestell. Lampenschirm und Deckenbaldachin bestehen aus seidigen Stoffstreifen in den Farben beige oder schwarz. Das Innenteil ist mit einem halbreflektierenden, verchromten Blatt ausgestattet.

Collection complète de lampes avec finition chromée. L'abat-jour et la rosace sont constitués par des rubans en soie couleur ivoire ou noire ainsi que par une feuille interne semi-réfléchissante finition chrome.

Colección completa de lámparas con acabado cromo. La pantalla y el rosetón están formados por cintas de seda de color marfil o negro y por una lámina interior semireflejante con acabado en cromo.

Полная коллекция светильников с хромым покрытием. Абажур и розетка состоят из шелковистых кусочков черного цвета или цвета слоновой кости и внутреннего хромированного полупрозрачного листа.







1



- 1 SP OBI 20
- 2 AP OBI
- 3 AP OBI (DETAIL)

2



3













- 1 SP OBI 100 (DETAIL)
- 2 SP OBI 63/43 (DETAIL)
- 3 SP OBI 20 (DETAIL)

1



2



3





LT OBI (DETAIL)



LT OBI / AP OBI







PL OBI (DETAIL)

1



- 1 TAGLIO TUBI QUADRI IN METALLO  
CUTTING A SQUARE METAL TUBE
- 2 MONTATURE METALLICHE DOPO  
LA TORNITURA IN LASTRA  
METAL FRAMES AFTER SHEAR SPINNING
- 3 CROMATURA GALVANICA  
DELLE PARTI METALLICHE  
GALVANIZING CHROME METAL PARTS
- 4 LUCIDATURA DELLE PARTI METALLICHE  
POLISHING METAL PARTS
- 5 MONTAGGIO COMPONENTI  
ASSEMBLY
- 6 INTRECCIO EFFETTUATO A MANO  
CON FETTUCCIA SETATA SUI PARALUMI  
INTERLACING SILKEN RIBBON ON THE  
LAMP SHADES BY HAND

2



4



3



5



6



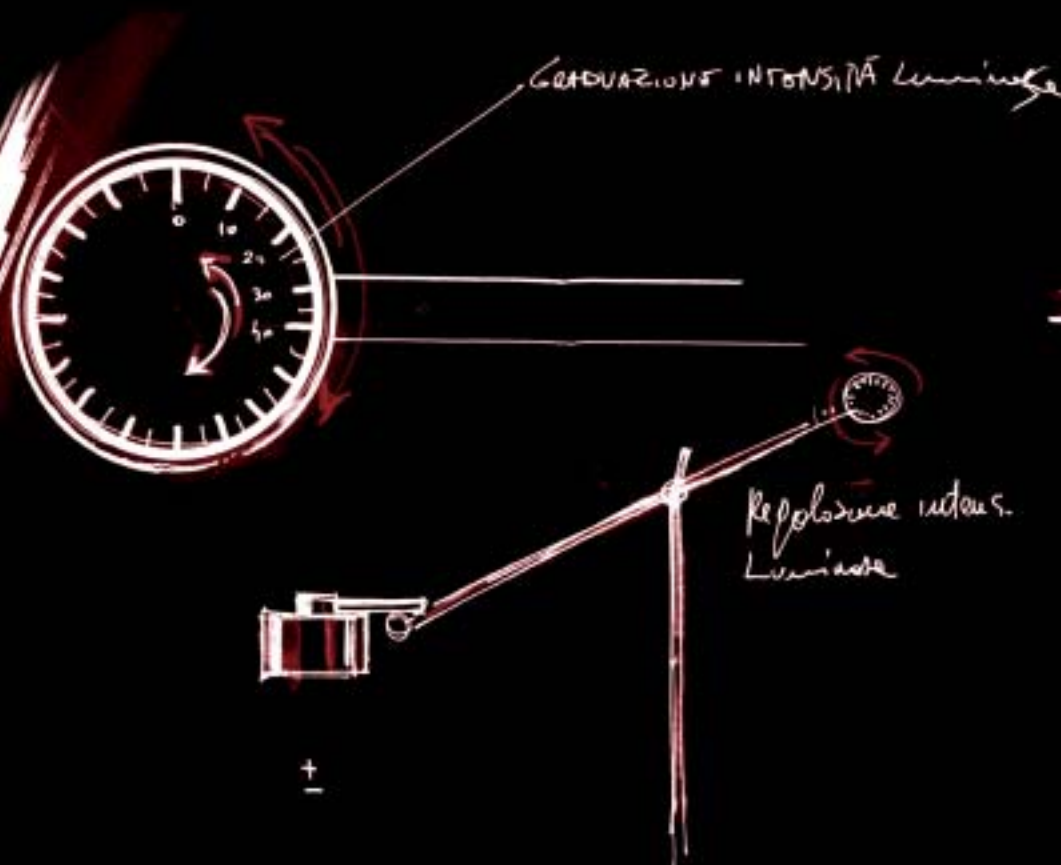

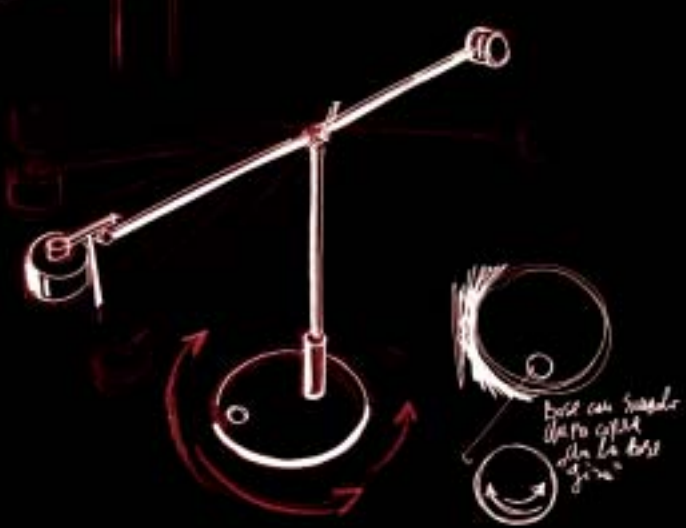
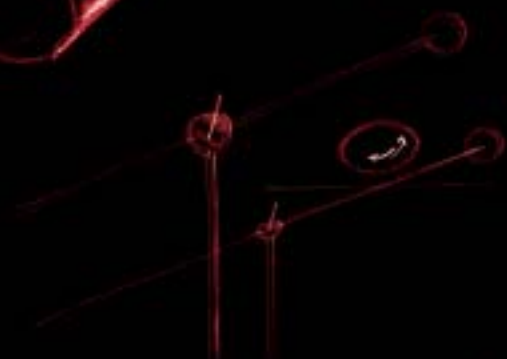
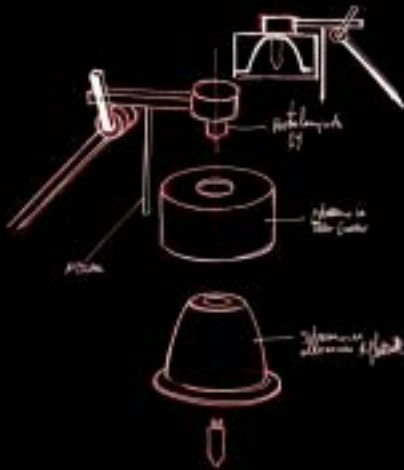

AX20

# AX20



Collezione completa di lampade in ottone e ferro finiti cromo con regolazione direzionale del fascio luminoso.

Complete lamp collection made of brass and iron with a chrome-plated finish. The direction of the light beam can be manually adjusted.

Komplette Leuchtenkollektion, Grundmaterial bestehend aus verchromten Messing und Eisen. Dimmbare Lichtregulierung.

Collection complète de lampes en laiton et fer finition chrome avec réglage directionnel du flux lumineux.

Colección completa de lámparas de latón y hierro con acabados de cromo y con regulación direccional del haz luminoso

Коллекция светильников из хромированной латуни и железа, с регулированием направления светового потока.





- 1 LT AX20 (DIMMER DETAIL)
- 2 LT AX20 (DETAIL)
- 3 PT AX20 / LT AX20
- 4 AP AX20 PI / LT AX20





4





AP AX20 GR











SP AX20 PI (DETAIL)



SP AX20 B1





SP AX20 B2

1



2



3



4

5



- 1 TAGLIO TUBI QUADRI IN OTTONE  
CUTTING SQUARE BRASS TUBES
- 2 FORATURA E FRESATURA DI PARTI  
IN OTTONE DAL PIENO  
DRILLING AND MILLING OF SOLID  
BRASS PARTS
- 3 SALDATURA BRACCI IN OTTONE  
WELDING BRASS SUPPORTS
- 4 LUCIDATURA E CROMATURA GALVANICA  
DELLE PARTI METALLICHE  
POLISHING AND GALVANIZING CHROME  
METAL PARTS
- 5 VERNICIATURA GOMMATA GRIP NERA  
DI ALCUNE PARTI METALLICHE  
SPRAYING METAL PARTS WITH BLACK  
RUBBERIZED PAINT
- 6 MONTAGGIO COMPONENTI  
ASSEMBLY

6



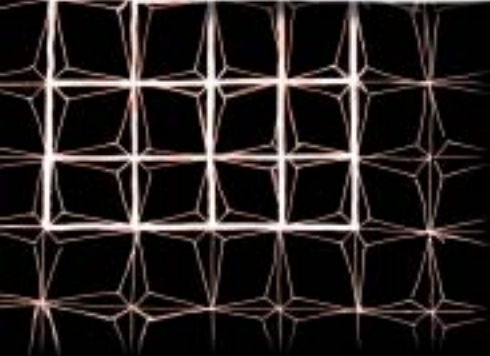
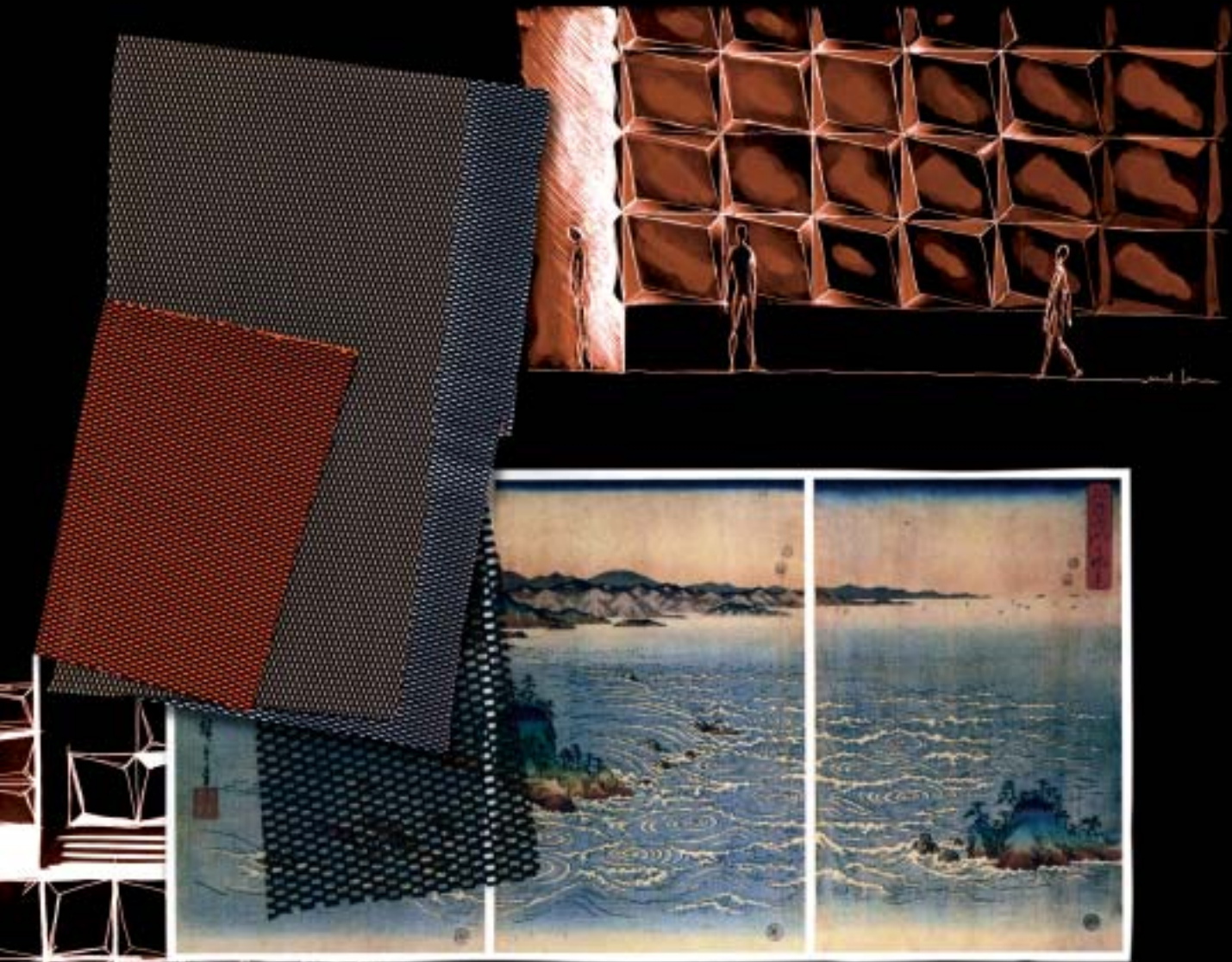

La Rete elastica "libera" con un fondo di contrasto + scuro  
 elemento chiave degli effetti + tridimensionalità

usare Rete elastica con un fondo cupreo

500 piani "tessuto" + elastici

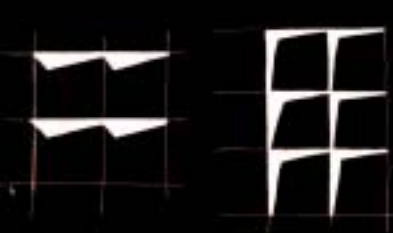



*scarsazione del mare increspato*

*1953 per Mario  
Pulcinella Cirillo*

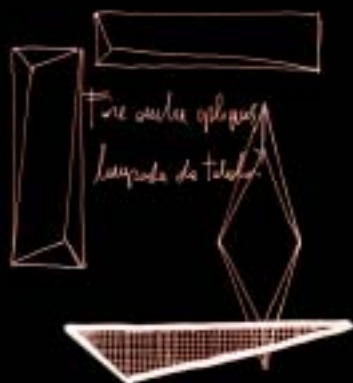
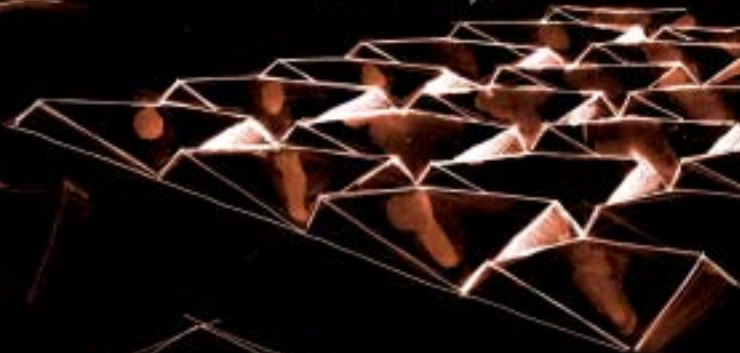

*Tre caselle oploque  
laquada da tela*

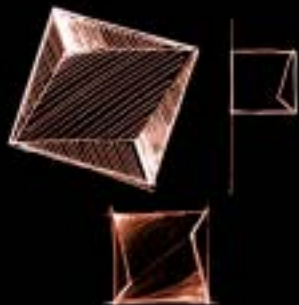

*potrebbe essere usata  
come pannello abaco*

*Handwritten Japanese calligraphy in vertical columns, including a red seal at the bottom.*

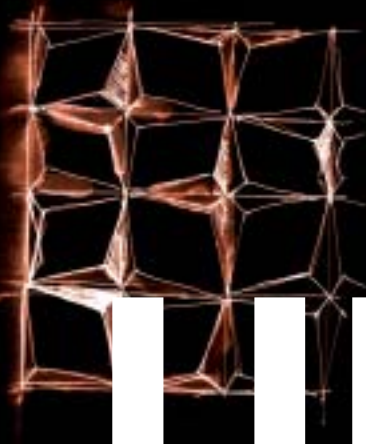
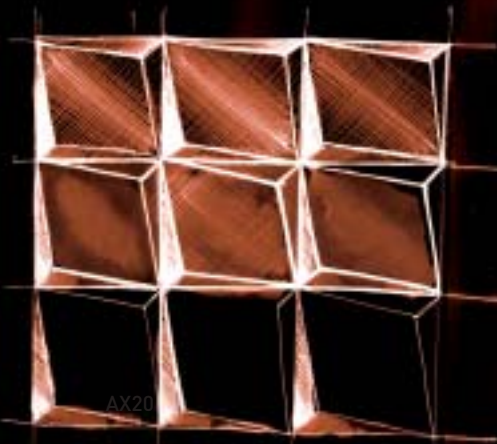

*Forma Medeloni*

# UKIYO



Collezione di lampade da parete e da soffitto in tessuto tecnico elastico retato a due strati. Disponibile in tre tonalità: fondo bianco e rete bianca, fondo arancio e rete nera, fondo bianco e rete nera.

Wall and ceiling lamp collection made with a special covering composed of two overlapping elastic fabrics. Available in three shades: white background covered with white netting, orange background with black net on top, white background with black net on top.

Leuchtenkollektion bestehen aus Wand- und Deckenleuchte, bezogen mit einem elastischem Netz-Technostoff, bestehend aus zwei Stofflagen. In drei Farbtönen erhältlich: Grundstoff weiß mit weißem Netz, Grundstoff orange mit schwarzem Netz, Grundstoff weiß und schwarzem Netz.

Collection d'appliques et de plafonniers en tissu technique élastique réticulé à deux couches. Disponible en trois tonalités : fond blanc et résille blanche, fond orange et résille noire, fond blanc et résille noire.

Colección de lámparas de pared y de techo en tejido técnico elástico con retículo de dos capas. Disponible en tres tonalidades: fondo blanco y red blanca, fondo anaranjado y red negra, fondo blanco y red negra.

Коллекция настенных и потолочных светильников из технической эластичной сетчатой двухслойной ткани. Предлагается выбор из трех расцветок: белый фон и белая сетка, оранжевый фон и черная сетка, белый фон и черная сетка.









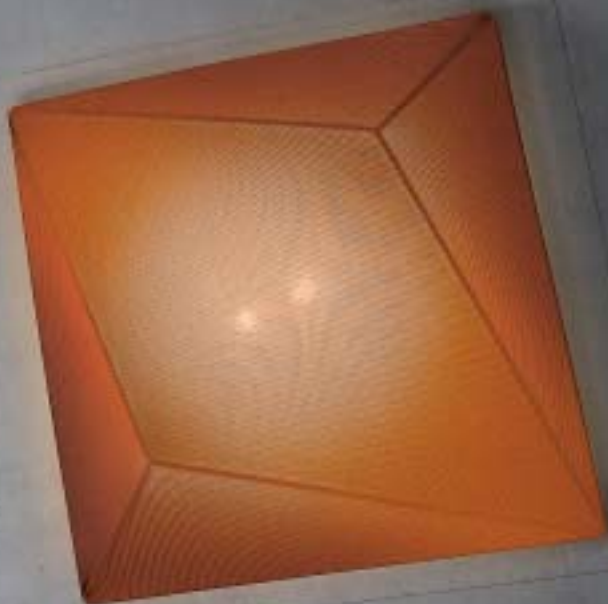
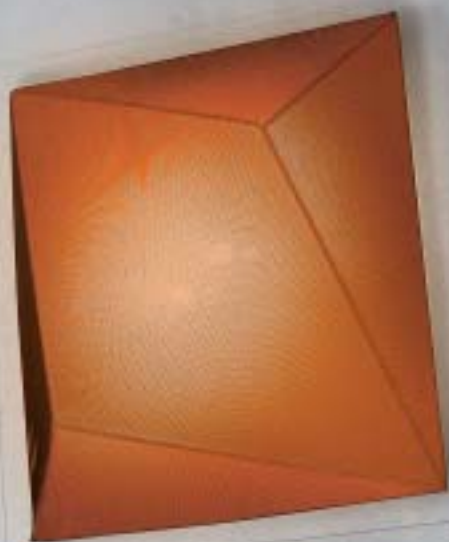

PL UKI 110 / PL UKIYO P

1



- 1 PL UKI 110
- 2 PL UKIYO P (DETAIL)
- 3 PL UKIYO P (DETAIL)

2



3





PL UKIYO ON OFF





- 1 PIEGATURA DEI TONDINI MEDIANTE  
PIEGATRICE A CONTROLLO NUMERICO 3D  
BENDING NARROW RODS USING A 3D  
NUMERICAL CONTROL MACHINE
- 2 SALDATURA DEI TONDINI  
CON PUNTATRICE ELETTRICA  
SPOT WELDING NARROW RODS
- 3 CONTROLLO DELLA MONTATURA  
CONTROLLING FRAME QUALITY
- 4 TAGLIO DELLA STOFFA  
CUTTING FABRIC
- 5 CUCITURA DELLA STOFFA E INSERIMENTO  
DELL'ELASTICO  
SEWING FABRIC AND INSERTING ELASTIC

3

4



5



TESK 50

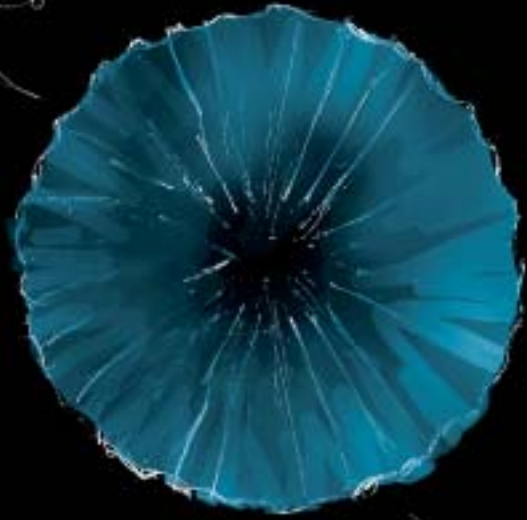

Sawarna  
Kembang







SCHEMATA

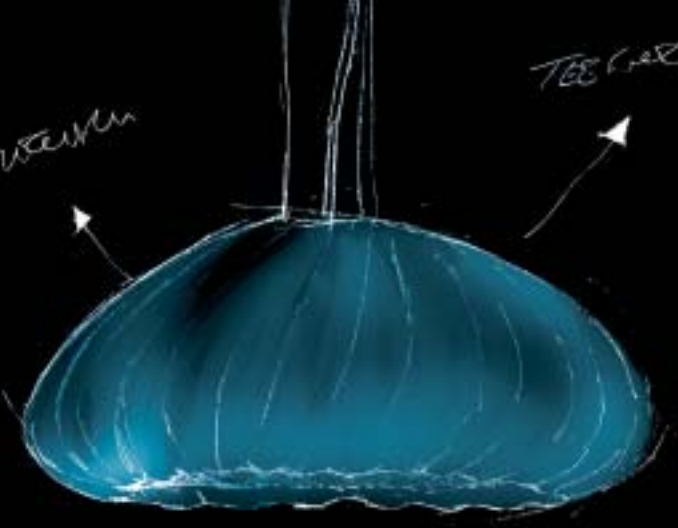

CHINA PAPER 30cm  
in CE 8WTO



# MUSE



PL MUS 120 YELLOW

Collezione di lampade con struttura metallica e rivestimento in tessuto elasticizzato, sfoderabile e lavabile. Il tessuto è ora disponibile anche nei seguenti colori: giallo, arancio, rosso, fucsia, rosa, viola, blu, azzurro, verde e multicolore.

Lamp collection consisting of a metal structure and a covering made of a removable and washable elastic fabric. The fabric is now also available in the following colors: yellow, orange, red, fuchsia, pink, violet, dark blue, light blue, green and multicolour.

Leuchtenkollektion, Struktur aus Metall und überzogen mit einem elastischem Stoff, abnehmbar und waschbar. Nun sind auch folgende Farbtöne lieferbar: gelb, orange, rot, pink, rosa, violett, blau, hellblau, grün und mehrfarbig.

Collection de lampes avec une structure métallique et un revêtement en tissu élastique, amovible et lavable. Le tissu est maintenant disponible également dans les coloris suivants: jaune, orange, rouge, fuchsia, rose, violet, bleu, bleu clair, vert et multicolore.

Colección de lámparas con estructura metálica y revestimiento en tejido perlado elasticado, desfundable y lavable. El tejido se encuentra también disponible en los siguientes colores: amarillo, anaranjado, rojo, fucsia, rosa, violeta, azul marino, azul cielo, verde y multicolor.

Коллекция светильников с металлической структурой и съёмным абажуром из моющейся эластичной ткани. Сегодня можно выбрать также абажуры следующих цветов: желтый, оранжевый, красный, фуксия, розовый, фиолетовый, синий, голубой, зеленый и разноцветный.

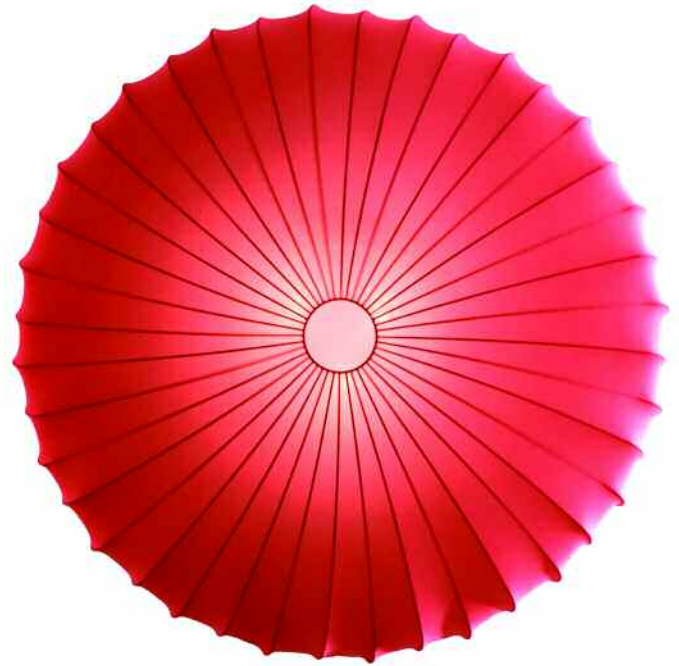







PL MUSE 80 (DETAIL)



SP MUSE / PL MUSE 80 LIGHT BLUE







PL MUSE 80 (DETAIL)





PL MUS 120 / SP MUSE MULTICOLOR



PL MUS 120 VIOLET



PL MUS 120 DARK BLUE



PL MUS 120 LIGHT BLUE



PL MUS 120 GREEN



PL MUS 120 YELLOW



PL MUS 120 PINK



PL MUS 120 ORANGE



PL MUS 120 RED



PL MUS 120 FUCHSIA

PL MUS 120 WHITE  
PL MUS 120 MUTICOLOR

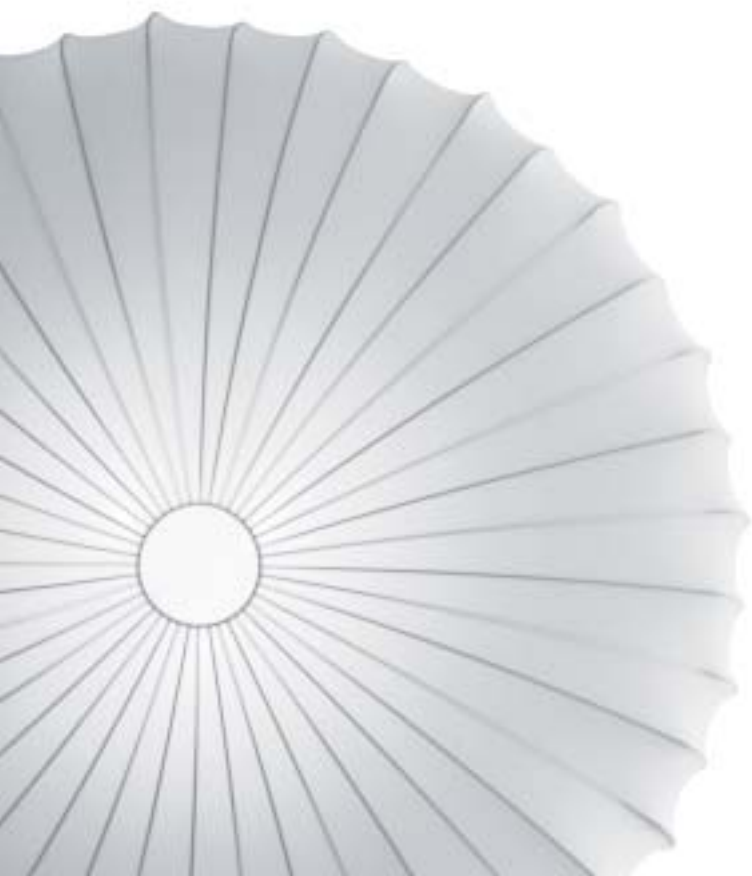





- 1 PL MUS 120 / PL MUSE 80
- 2 PL MUSE 80 (DETAIL)
- 3 SP MUSE (DETAIL)
- 4 SP MUSE

1



2





3



4





- 1 PIEGATURA DEI TONDINI MEDIANTE  
PIEGATRICE A CONTROLLO NUMERICO 3D  
BENDING NARROW RODS USING A 3D  
NUMERICAL CONTROL MACHINE
- 2 SALDATURA DEI TONDINI  
CON PUNTATRICE ELETTRICA  
SPOT WELDING NARROW RODS
- 3 CUCITURA DELLA STOFFA  
SEWING FABRIC
- 4 INSERIMENTO DELL'ELASTICO  
INSERTING ELASTIC
- 5 IMBALLAGGIO STOFFA  
PACKING FABRIC



1



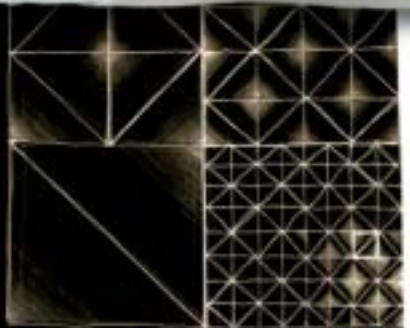

E. Castellani, Estoflamm

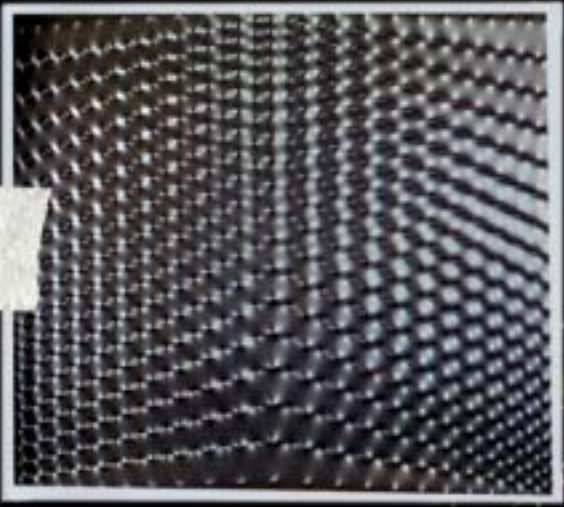

panelli a 4° angolo

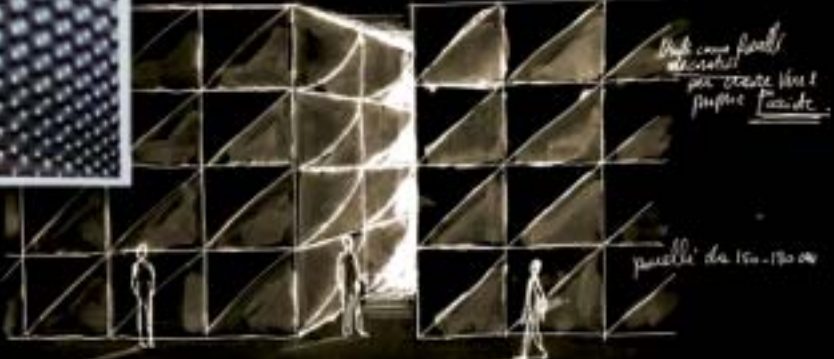

Dati come fogli  
decorati  
per essere visti  
proprio facile.

panelli da 150-170 cm

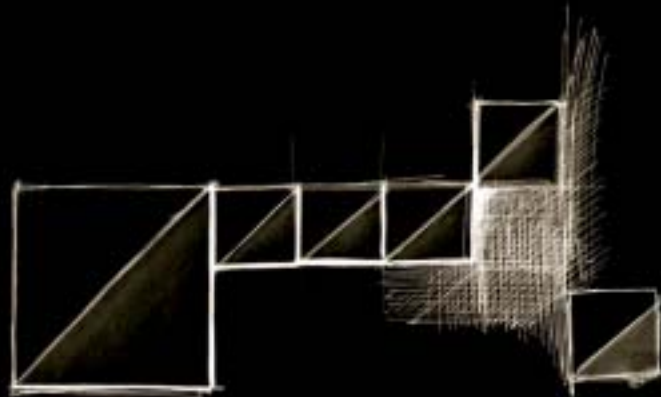

*forma una lingua*

*Tessuto*

*La tensione del tessuto  
ha una curva  
che è l'ombra*



*il Tondolo delle due  
forme, l'ombreggiatura  
e il soffio l'ombra*



*Concetto Vestire come lingua  
con la luce, come  
Vestire una bella donna*



*Possibilità di  
Polar come Fibra  
l'ombreggiatura, l'ombra  
di l'ombra effetto*



# NELLY



Collezione di lampade in tessuto elastico sfoderabile e lavabile. Disponibile in bianco, fantasia bianco e fantasia avorio. La plafoniera è ora prodotta anche nella versione quadrata di dimensioni 140x140 cm e nella versione circolare di diametro 140 cm.

Lamp collection made with coverings of removable and washable elastic fabric. Available in white, white pattern and ivory pattern. The ceiling lamp is now available in a square shape measuring 140x140 cm and in a circular shape having a diameter of 140 cm.

Leuchtenkollektion aus elastischem Stoff, abnehmbar und waschbar. Verfügbar in weiß, Dekor weiß und Dekor beige. Die Deckenleuchte wird nun auch in folgenden Größen produziert: quadratisch 140x140 cm sowie rund Ø 140 cm.

Collection de lampes en tissu élastique amovible et lavable. Disponible en blanc, blanc fantaisie et ivoire fantaisie. Le plafonnier est produit maintenant également dans la version carrée avec les dimensions 140x140 cm et dans la version circulaire d'un diamètre de 140 cm.

Colección de lámparas en tejido elástico desfundable y lavable. Disponible en blanco, fantasía blanco y fantasía marfil. La luminaria se fabrica también en la versión cuadrada de tamaño 140x140 cm y en la versión circular de 140 cm de diámetro.

Коллекция светильников со съёмным абажуром из эластичной моющейся ткани. Три варианта расцветки: белый, белый с рисунком и цвета слоновой кости с рисунком. В настоящее время выпускается также модификации с квадратным плафоном размером 140x140 см и с круглым плафоном диаметром 140 см.











NELLY Q COMPOSITION (140 / 100 / 60)







1



2



- 1 AP NELL BR / SP NELL 90  
PT NELL 60
- 2 LT NELLY G / LT NELLY P (DETAIL)
- 3 PT NELL 60

3



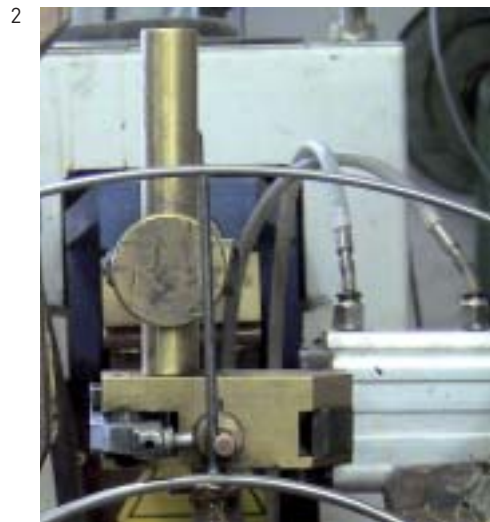





- 1 PIEGATURA DEI TONDINI MEDIANTE  
PIEGATRICE A CONTROLLO NUMERICO 3D  
BENDING NARROW RODS USING A 3D  
NUMERICAL CONTROL MACHINE
- 2 SALDATURA DEI TONDINI  
CON PUNTATRICE ELETTRICA  
SPOT WELDING NARROW RODS
- 3 CUCITURA DELLA STOFFA  
SEWING FABRIC
- 4 INSERIMENTO DELL'ELASTICO  
INSERTING ELASTIC
- 5 IMBALLAGGIO DOPO VERNICIATURA  
PACKING AFTER COATING  
OF METAL FRAMES





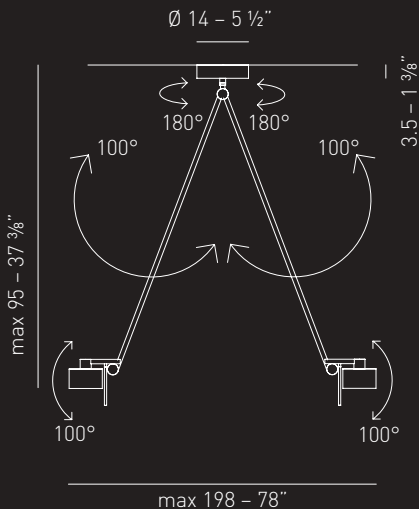
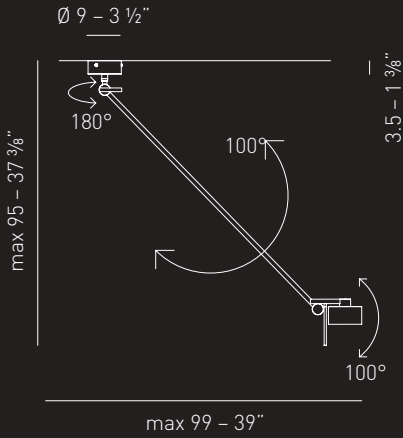
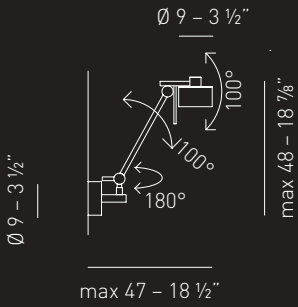
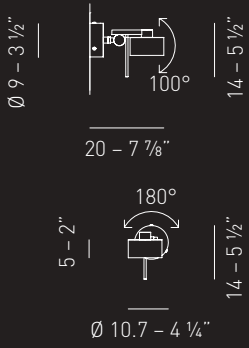





AP AX20 PI

EUROPE





watt 1 x max 60 w  
 bulb/ilcos HSGST/F/UB   
 socket 1 x G9  
 data CE   

NORTH AMERICA

watt 1 x max 60 w  
 bulb shape JD frost   
 bulb base 1 x G9

AP AX20 GR

EUROPE





watt 1 x max 60 w  
 bulb/ilcos HSGST/F/UB   
 socket 1 x G9  
 data CE   

NORTH AMERICA

watt 1 x max 60 w  
 bulb shape JD frost   
 bulb base 1 x G9

SP AX20 B1

EUROPE





watt 1 x max 60 w  
 bulb/ilcos HSGST/F/UB   
 socket 1 x G9  
 data CE   

NORTH AMERICA

watt 1 x max 60 w  
 bulb shape JD frost   
 bulb base 1 x G9

SP AX20 B2

EUROPE

watt 2 x max 60 w  
 bulb/ilcos HSGST/F/UB   
 socket 2 x G9  
 data CE   

NORTH AMERICA

watt 2 x max 60 w  
 bulb shape JD frost   
 bulb base 2 x G9

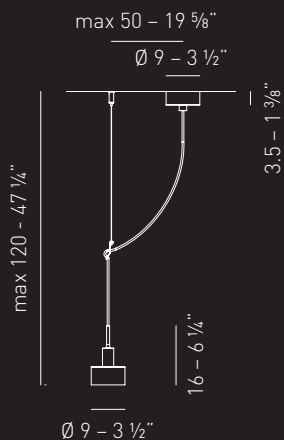

Ø 9 - 3 1/2"

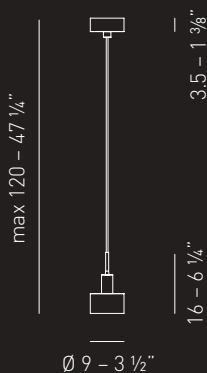

Ø 9 - 3 1/2"

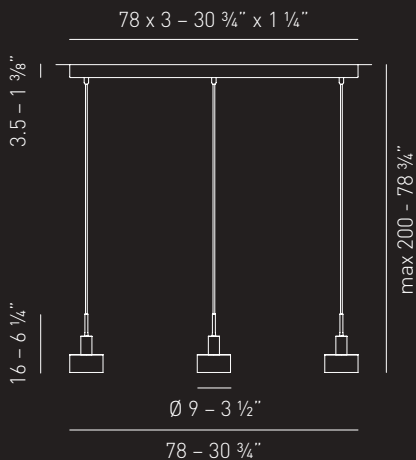

Ø 9 - 3 1/2"



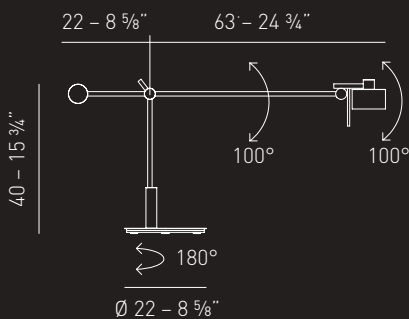

78 - 30 3/4"



Ø 22 - 8 5/8"

**SP AX20 DE**

**EUROPE**



watt 1 x max 60 w  
 bulb/ilcos HSGST/F/UB   
 socket 1 x G9  
 data CE   

**NORTH AMERICA**

watt 1 x max 60 w  
 bulb shape JD frost   
 bulb base 1 x G9

**SP AX20 PI**

**EUROPE**





watt 1 x max 60 w  
 bulb/ilcos HSGST/F/UB   
 socket 1 x G9  
 data CE   

**NORTH AMERICA**

watt 1 x max 60 w  
 bulb shape JD frost   
 bulb base 1 x G9

**SP AX20 3**

**EUROPE**



watt 3 x max 60 w  
 bulb/ilcos HSGST/F/UB   
 socket 3 x G9  
 data CE   

**NORTH AMERICA**



watt 3 x max 60 w  
 bulb shape JD frost   
 bulb base 3 x G9

**LT AX20**

**EUROPE**

watt 1 x max 60 w  
 bulb/ilcos HSGST/F/UB   
 socket 1 x G9  
 data CE    



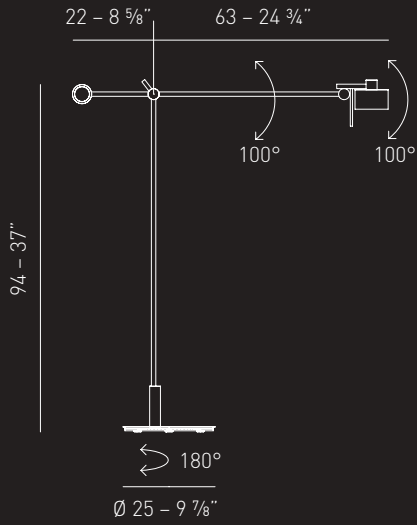

**NORTH AMERICA**

watt 1 x max 60 w  
 bulb shape JD frost   
 bulb base 1 x G9  
 data 





**PT AX20**

**EUROPE**

watt 1 x max 60 w  
 bulb/ilcos HSGST/F/UB   
 socket 1 x G9  
 data    

**NORTH AMERICA**

watt 1 x max 60 w  
 bulb shape JD frost   
 bulb base 1 x G9  
 data 

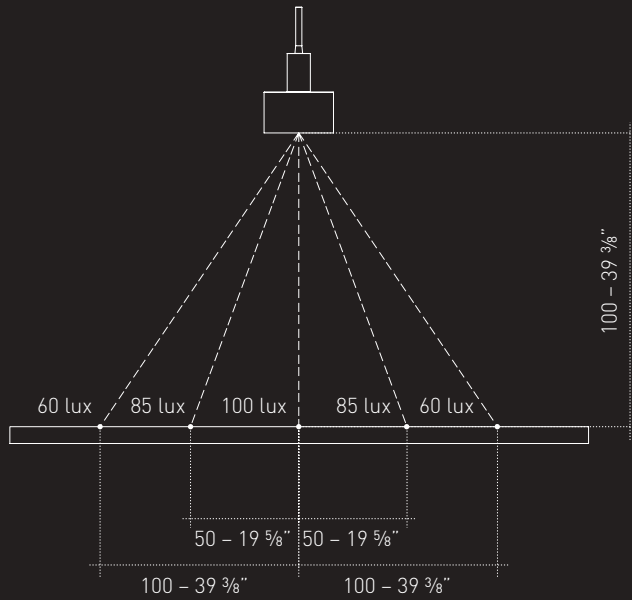
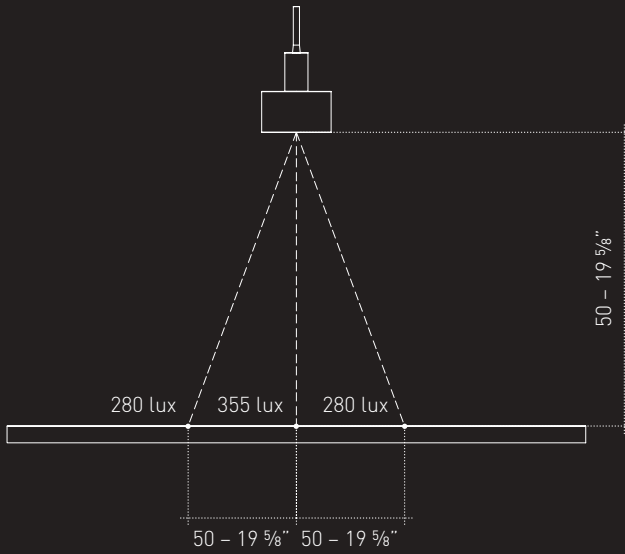

Valori riferiti ad un illuminamento medio di 0 lux (rilievo fatto in stanza buia con pareti bianche)

Measures referred to an average illuminance value of 0 lux (100% dark room with white wall)

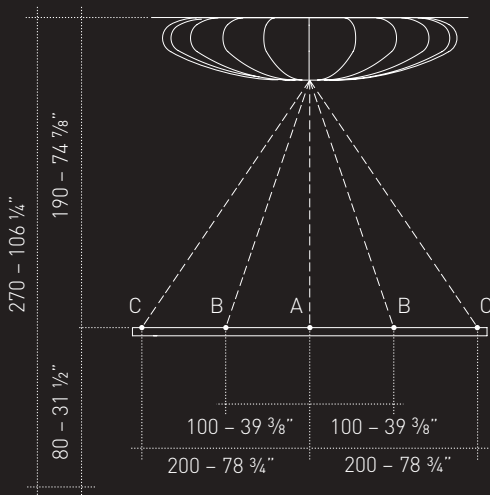
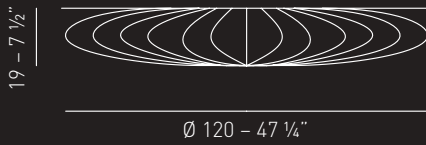

**PL MUS 120**

**EUROPE**

watt 3 x max 100 w  
 bulb/ilcos IAA/W   
 socket 3 x E27  
 data

watt 1 x max 55 w  
 bulb/ilcos FSC   
 socket 1 x 2GX13  
 data

**NORTH AMERICA**

watt 3 x max 100 w  
 bulb shape A-19 white   
 bulb base 3 x medium E26

watt 1 x max 55 w  
 bulb shape T5   
 bulb base 1 x 2GX13

**MUSE PL 120 WHITE**

Code PLMUS120BCXXE27  
 Pantone 116 C

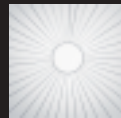

illuminance value  
 A = 190 lux  
 B = 146 lux  
 C = 85 lux

**MUSE PL 120 VIOLET**

Code PLMUS120VIXXE27  
 Pantone 2645 C

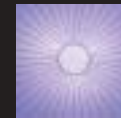

illuminance value  
 A = 59 lux  
 B = 43 lux  
 C = 28 lux

**MUSE PL 120 DARK BLUE**

Code PLMUS120BLXXE27  
 Pantone 072 C



illuminance value  
 A = 19 lux  
 B = 16 lux  
 C = 10 lux

**MUSE PL 120 LIGHT BLUE**

Code PLMUS120AZXXE27  
 Pantone 306 C

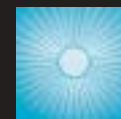

illuminance value  
 A = 45 lux  
 B = 34 lux  
 C = 22 lux

**MUSE PL 120 GREEN**

Code PLMUS120VEXXE27  
 Pantone 3385 C

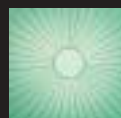

illuminance value  
 A = 54 lux  
 B = 39 lux  
 C = 25 lux

**MUSE PL 120 YELLOW**

Code PLMUS120GIXXE27  
 Pantone 116 C

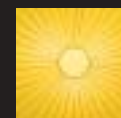

illuminance value  
 A = 115 lux  
 B = 86 lux  
 C = 54 lux

**MUSE PL 120 PINK**

Code PLMUS120ROXXE27  
Pantone 211 C

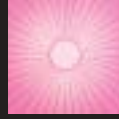

illuminance value  
A = 86 lux  
B = 65 lux  
C = 41 lux

**MUSE PL 120 ORANGE**

Code PLMUS120ARXXE27  
Pantone 021 C

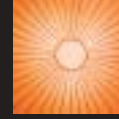

illuminance value  
A = 80 lux  
B = 58 lux  
C = 37 lux

**MUSE PL 120 RED**

Code PLMUS120RSXXE27  
Pantone 200 C

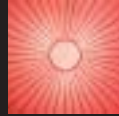

illuminance value  
A = 43 lux  
B = 32 lux  
C = 22 lux

**MUSE PL 120 FUCHSIA**

Code PLMUS120FUXXE27  
Pantone 233 C

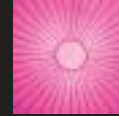

illuminance value  
A = 50 lux  
B = 37 lux  
C = 23 lux

**MUSE PL 120 MULTICOLOR**

Code PLMUS120MCXXE27



illuminance value  
A = 90 lux  
B = 64 lux  
C = 42 lux

Valori riferiti ad un illuminamento medio di 0 lux (rilievo fatto in stanza buia con pareti bianche)  
Il riferimento colore Pantone è stato rilevato con luce ambiente a 5000 K

Measures referred to an average illuminance value of 0 lux (100% dark room with white wall)  
Pantone color reference was settled using 5000 K light.



19 - 7 1/2"

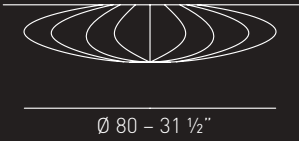

Ø 80 - 31 1/2"

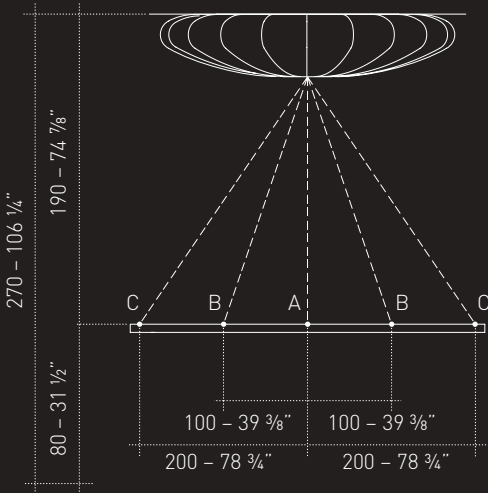

**PL MUSE 80**

**EUROPE**

watt 3 x max 100 w  
 bulb/ilcos IAA/W   
 socket 3 x E27  
 data

watt 1 x max 55 w  
 bulb/ilcos FSC   
 socket 1 x 2GX13  
 data

**NORTH AMERICA**

watt 3 x max 100 w  
 bulb shape A-19 white   
 bulb base 3 x medium E26

watt 1 x max 55 w  
 bulb shape T5   
 bulb base 1 x 2GX13

**MUSE PL 80 WHITE**

Code PLMUSE80BCXXE27  
 Pantone 116 C



illuminance value  
 A = 170 lux  
 B = 116 lux  
 C = 69 lux

**MUSE PL 80 VIOLET**

Code PLMUSE80VIXXE27  
 Pantone 2645 C



illuminance value  
 A = 62 lux  
 B = 44 lux  
 C = 30 lux

**MUSE PL 120 DARK BLUE**

Code PLMUSE80BLXXE27  
 Pantone 072 C

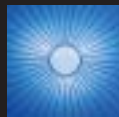

illuminance value  
 A = 24 lux  
 B = 19 lux  
 C = 14 lux

**MUSE PL 80 LIGHT BLUE**

Code PLMUSE80AZXXE27  
 Pantone 306 C

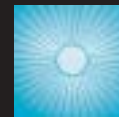

illuminance value  
 A = 47 lux  
 B = 36 lux  
 C = 24 lux

**MUSE PL 80 GREEN**

Code PLMUSE80VEXXE27  
 Pantone 3385 C



illuminance value  
 A = 55 lux  
 B = 42 lux  
 C = 29 lux

**MUSE PL 80 YELLOW**

Code PLMUSE80GIXXE27  
 Pantone 116 C



illuminance value  
 A = 105 lux  
 B = 75 lux  
 C = 52 lux

**MUSE PL 80 PINK**

Code PLMUSE80ROXXE27  
Pantone 211 C

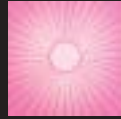

illuminance value  
A = 83 lux  
B = 58 lux  
C = 40 lux

**MUSE PL 80 ORANGE**

Code PLMUSE80ARXXE27  
Pantone 021 C

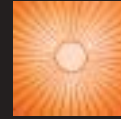

illuminance value  
A = 72 lux  
B = 52 lux  
C = 35 lux

**MUSE PL 80 RED**

Code PLMUSE80RSXXE27  
Pantone 200 C

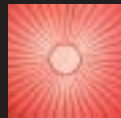

illuminance value  
A = 43 lux  
B = 33 lux  
C = 23 lux

**MUSE PL 80 FUCHSIA**

Code PLMUSE80FUXXE27  
Pantone 233 C

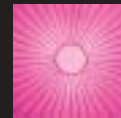

illuminance value  
A = 48 lux  
B = 36 lux  
C = 24 lux

**MUSE PL 80 MULTICOLOR**

Code PLMUSE80MCXXE27

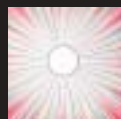



illuminance value  
A = 80 lux  
B = 55 lux  
C = 35 lux

Valori riferiti ad un illuminamento medio di 0 lux (rilievo fatto in stanza buia con pareti bianche)  
Il riferimento colore Pantone è stato rilevato con luce ambiente a 5000 K

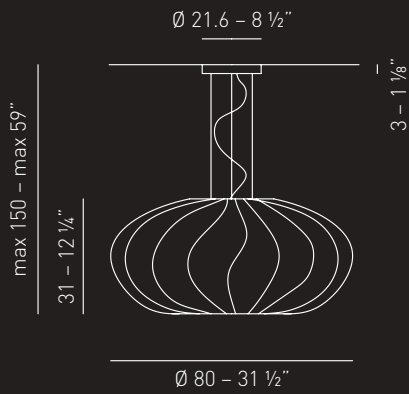
Measures referred to an average illuminance value of 0 lux (100% dark room with white wall)  
Pantone color reference was settled using 5000 K light.

**SP MUSE****EUROPE**

watt 1 x max 150 w  
 bulb/ilcos IAG/W globe   
 socket 1 x E27 globe  
 data  

watt 1 x max 21 w  
 bulb/ilcos FBG globe fluo   
 socket 1 x E27  
 data  

**NORTH AMERICA**

watt 1 x max 150 w  
 bulb shape G-40 globe white   
 bulb base 1 x medium E26

watt 1 x max 25 w  
 bulb shape G-30 globe fluo   
 bulb base 1 x medium E26

**SP MUSE WHITE**

Code SPMUSEXXBCXXE27  
 Pantone 211 C



illuminance value  
 D = 280 lux  
 E = 110 lux  
 F = 70 lux

Valori riferiti ad un illuminamento medio di 0 lux [rilievo fatto in stanza buia con pareti bianche]  
 Il riferimento colore Pantone è stato rilevato con luce ambiente a 5000 K

Measures referred to an average illuminance value of 0 lux (100% dark room with white wall)  
 Pantone color reference was settled using 5000 K light.

22 - 8 5/8"

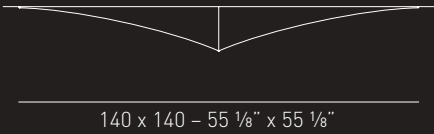

140 x 140 - 55 1/8" x 55 1/8"

**PL NE Q 140**

**EUROPE**

watt 4 x max 100 w  
 bulb/ilcos IAA/F   
 socket 4 x E27  
 data CE

watt 1 x max 55 w  
 bulb/ilcos FSC   
 socket 1 x 2GX13  
 data CE

**NORTH AMERICA**

watt 4 x max 100 w  
 bulb shape A-19 frost   
 bulb base 4 x medium base E26

watt 1 x max 55 w  
 bulb shape T5   
 bulb base 1 x 2GX13

22 - 8 5/8"



Ø 140 - 55 1/8"

**PL NEL 140**

**EUROPE**

watt 4 x max 100 w  
 bulb/ilcos IAA/F   
 socket 4 x E27  
 data CE

watt 1 x max 55 w  
 bulb/ilcos FSC   
 socket 1 x 2GX13  
 data CE

**NORTH AMERICA**

watt 4 x max 100 w  
 bulb shape A-19 frost   
 bulb base 4 x medium base E26

watt 1 x max 55 w  
 bulb shape T5   
 bulb base 1 x 2GX13

For other sizes look into the general catalogue

**OBI**

Ø 63 - 24 3/4"

Ø 60 - 23 5/8"

177 - 69 5/8"

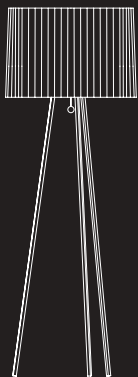

43 - 16 7/8"

Ø 57 - 22 1/2"

**PT OBI**

**EUROPE**

watt 3 x max 100 w  
 bulb/ilcos IAA/C   
 socket 3 x E27  
 data CE

watt 3 x max 20 w  
 bulb/ilcos FBA   
 socket 3 x E27  
 data CE

**NORTH AMERICA**

watt 3 x max 100 w  
 bulb shape A-19 clear   
 bulb base 3 x medium base E26

watt 3 x max 20 w  
 bulb shape A-19 fluo   
 bulb base 3 x medium base E26

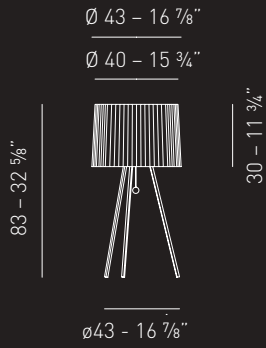

**LT OBI**

**EUROPE**

watt 3 x max 60 w  
 bulb/ilcos IAA/C   
 socket 3 x E27  
 data CE

**NORTH AMERICA**

watt 3 x max 60 w  
 bulb shape A-19 clear   
 bulb base 3 x medium base E26

watt 3 x max 10 w  
 bulb/ilcos FBA   
 socket 3 x E27  
 data CE

watt 3 x max 11 w  
 bulb shape A-19 fluo   
 bulb base 3 x medium base E26

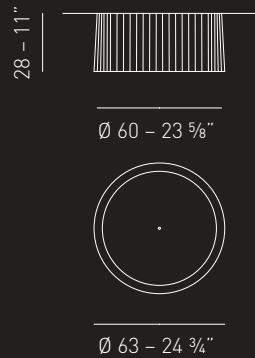

**PL OBI**

**EUROPE**

watt 3 x max 100 w  
 bulb/ilcos IAA/C   
 socket 3 x E27  
 data CE

**NORTH AMERICA**

watt 3 x max 100 w  
 bulb shape A-19 clear   
 bulb base 3 x medium base E26

watt 3 x max 20 w  
 bulb/ilcos FBA   
 socket 3 x E27  
 data CE

watt 3 x max 20 w  
 bulb shape A-19 fluo   
 bulb base 3 x medium base E26

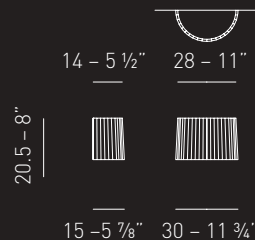

**AP OBI**

**EUROPE**

watt 2 x max 40 w  
 bulb/ilcos IBB/C   
 socket 2 x E14  
 data CE

**NORTH AMERICA**

watt 2 x max 40 w  
 bulb shape B-10 clear   
 bulb base 2 x candelabra E12

watt 2 x max 9 w  
 bulb/ilcos FBB   
 socket 2 x E14  
 data CE

watt 2 x max 9 w  
 bulb shape CANDLE   
 bulb base 2 x candelabra E12

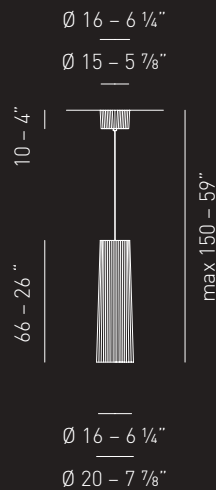

**SP OBI 20**

**EUROPE**

watt 1 x max 100 w  
 bulb/ilcos IAA/C   
 socket 1 x E27  
 data CE

**NORTH AMERICA**

watt 1 x max 100 w  
 bulb shape A-19 clear   
 bulb base 1 x medium base E26

watt 1 x max 20 w  
 bulb/ilcos FBA   
 socket 1 x E27  
 data CE

watt 1 x max 20 w  
 bulb shape A-19 fluo   
 bulb base 1 x medium base E26

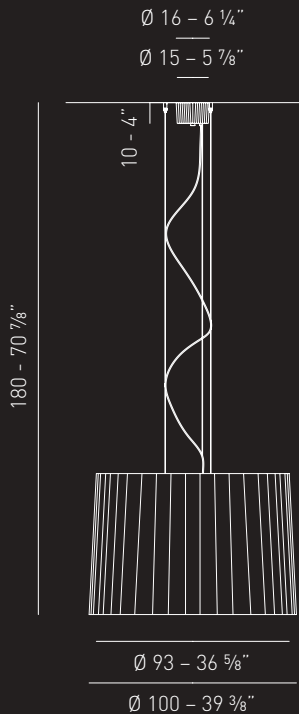
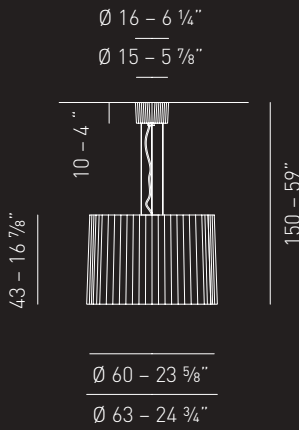
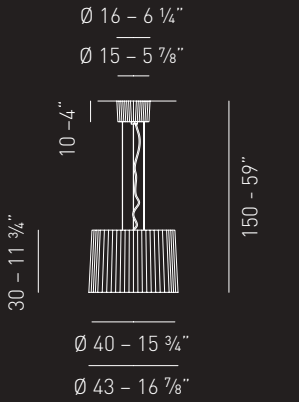

**SP OBI 43**

**EUROPE**

watt 3 x max 60 w  
 bulb/ilcos IAA/C   
 socket 3 x E27  
 data CE

watt 3 x max 20 w  
 bulb/ilcos FBA   
 socket 3 x E27  
 data CE

**NORTH AMERICA**

watt 3 x max 60 w  
 bulb shape A-19 clear   
 bulb base 3 x medium base E26

watt 3 x max 20 w  
 bulb shape A-19 fluo   
 bulb base 3 x medium base E26

**SP OBI 63**

**EUROPE**

watt 3 x max 100 w  
 bulb/ilcos IAA/C   
 socket 3 x E27  
 data CE

watt 3 x max 20 w  
 bulb/ilcos FBA   
 socket 3 x E27  
 data CE

**NORTH AMERICA**

watt 3 x max 100 w  
 bulb shape A-19 clear   
 bulb base 3 x medium base E26

watt 3 x max 20 w  
 bulb shape A-19 fluo   
 bulb base 3 x medium base E26

**SP OBI 100**

**EUROPE**

watt 6 x max 100 w  
 bulbs/ilcos IAA/C   
 socket 6 x E27  
 data CE



watt 6 x max 23 w  
 bulbs/ilcos FBT   
 socket 6 x E27  
 data CE

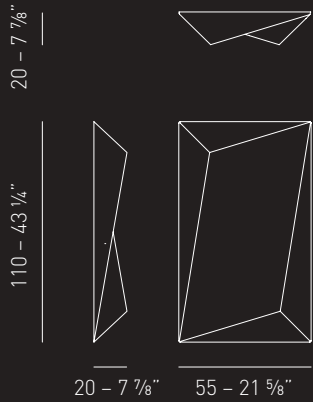

**NORTH AMERICA**

watt 6 x max 100 w  
 bulbs shape A-19 clear   
 bulb base 6 x medium base E26

watt 6 x max 23 w  
 bulbs shape TRIPLE PLAY   
 bulb base 6 x medium base E26

**PL UKI 110****EUROPE**

watt 3 x max 100 w  
 bulb/ilcos IAA/F   
 socket 3 x E27  
 data  



watt 1 x max 55 w  
 bulb/ilcos FSC   
 socket 1 x 2GX13  
 data  

**NORTH AMERICA**

watt 3 x max 100 w  
 bulb shape A-19 frost   
 bulb base 3 x medium base E26

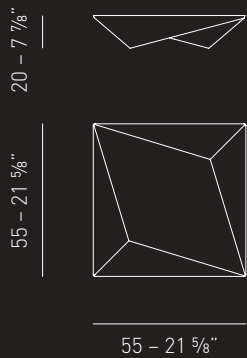
watt 1 x max 55 w  
 bulb shape T5   
 bulb base 1 x 2GX13

**PL UKIYO P****EUROPE**

watt 3 x max 60 w  
 bulb/ilcos IAA/F   
 socket 3 x E27  
 data  



watt 1 x max 55 w  
 bulb/ilcos FSC   
 socket 1 x 2GX13  
 data  

**NORTH AMERICA**

watt 3 x max 60 w  
 bulb shape A-19 frost   
 bulb base 3 x medium base E26

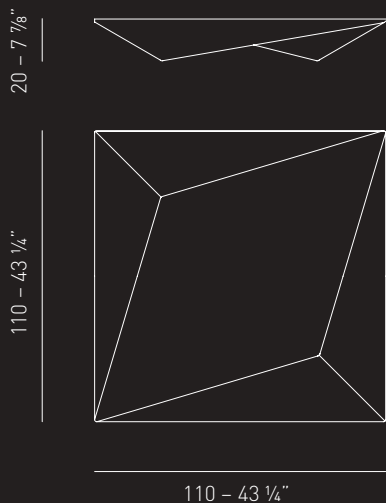
watt 1 x max 55 w  
 bulb shape T5   
 bulb base 1 x 2GX13

**PL UKIYO G****EUROPE**

watt 3 x max 100 w  
 bulb/ilcos IAA/F   
 socket 3 x E27  
 data  

watt 1 x max 55 w  
 bulb/ilcos FSC   
 socket 1 x 2GX13  
 data  

**NORTH AMERICA**

watt 3 x max 100 w  
 bulb shape A-19 frost   
 bulb base 3 x medium base E26

watt 1 x max 55 w  
 bulb shape T5   
 bulb base 1 x 2GX13



Prodotto sottoposto alle prove di sicurezza elettrica e conforme alle Direttive Comunitarie Europee EN60598-1

Product undergone to electric safety tests, conform to ECC Directive EN60598-1

Produkt entsprechend dereuropäischen Norm EN60598-1

Produit soumis aux tests de sécurité, conforme aux Directives CEE EN60598-1

Producto sometido a las pruebas de seguridad eléctrica y conforme con las directivas comunitarias europeas EN60598-1

Изделие подвержено электрическому испытанию. Оно соответствует указаниям Европейского Общества EN60598-1.



Apparecchi predisposti per il montaggio direttamente su superfici infiammabili

Fixtures prepared for the mounting on flammable surfaces

Geräte für Montage auf entflammbare Oberflächen geeignet sind

Appareils prévus pour le montage sur surfaces inflammables

Aparatos predispuestos para el montaje directamente sobre superficies inflamables

Изделия могут быть установлены на воспламеняющейся поверхности.



Solo isolamento fondamentale; le parti conduttrici accessibili sono collegate ad un conduttore di terra. Messa a terra obbligatoria

Basic insulation, accessible conductors are earthed. Earthing is obligatory

Grundisolation: berührbare Metallteile mit Anschlussstelle für Schutzleiter verbunden. Netzschutzleiter: vorgeschrieben.

Isolation de base: les parties conductrices accessibles sont mises à terre. Mise à terre obligatoire.

Solo aislamiento fundamental; las partes conductoras accesibles están conectadas a un conductor de tierra. Puesta a tierra obligatoria.

Изоляция только базовая. Доступные проводниковые части подсоединены к заземлителю. Заземление обязательно.





Sistema a doppio isolamento;  
messa a terra esclusa.

Double insulation. Earthing: excluded.

Doppelte Isolierung. Netzschutzleiter: nicht  
erlaubt.

Double isolation. Mise à la terre: exclue.

Sistema de doble aislamiento; puesta a tierra  
no incluida.

Система двойной изоляции. Заземление  
необязательно.

Predisposto con variatore di luce.

With dimmer.

Mit Dimmer.

Avec dimmer.

Con dimmer.

Предусмотрено с диммер.

Axo Light si riserva il diritto di apportare ai modelli, senza alcun preavviso, qualsiasi modifica ritenesse opportuna. Axo Light non risponde per eventuali danni a persone o cose causati da una non corretta installazione dei propri apparecchi d'illuminazione.

Axo Light reserves itself the right to introduce any changes to its own models, without prior notice. Axo Light is not liable for injuries or damage due to the incorrect installation of its fixtures.

Axo Light behält sich das Recht vor, jederzeit und ohne Voranmeldung, Änderungen der Kollektion vorzunehmen, ohne jedoch die charakteristischen Eigenschaften der Artikel zu ändern. Axo Light ist nicht verantwortlich für eventuelle Personen -oder Sachschäden, verursacht durch unsachgemäße Installation der Produkte.

Axo Light se réserve le droit de modifier ses collections à tous moments et sans préavis, dans le respect des caractéristiques de base du produit. Axo Light ne répond pas aux éventuels dommages à personnes ou choses causés par une mauvaise installation de ses appareils d'éclairage.

Axo Light se reserva el derecho de aportar a los propios modelos, sin ningún preaviso, cualquier modificación que se considere oportuna. Axo Light no responde por los eventuales daños causados a personas o cosas provocados por una incorrecta instalación de los propios aparatos de iluminación.

Axo Light оставляет за собой право вносить модификации моделей без предупреждения, в случае необходимости.

Axo Light не несёт ответственности за ущерб людям или вещам, вызванный некорректной установкой осветительных приборов.





